

Balcrank®

Tiger HP® Oil Pump Series

- Model 1130-019 Tiger HP® Bare Oil Pump, 6:1
Model 1130-025 Tiger HP® Bare Oil Pump, 6:1, Flange Mount
Model 1130-026* Tiger HP® Bare Oil Pump, 6:1, with Bung Adapter
Model 1160-007 Tiger HP® Bare Stainless Steel Pump, 6:1



*Model 1130-026 shown

Thoroughly read and understand this manual before installing, operating or servicing described equipment.

Operation, Installation, Maintenance and Repair Guide

General Safety

Thoroughly read and understand this manual before installing, operating or servicing the described products.



IMPORTANT

Because this pump can be incorporated into a pressurized systems, the following safety precautions should be observed.

Check equipment regularly and repair or replace worn and damaged parts.

Never alter or modify any parts of this pump, doing so may cause damage to pump and/or personal injury.

Under no circumstances should the dispensing valve be aimed at any person at any time. Personal injury may result.

Release pressures built up in the system before any service or repair is begun. See the pressure relief procedure below.

Do not operate this pump above 150 PSI (10.3 BAR) air inlet pressure or 200 cycles per minute.

Always read and follow the fluid manufacturer's recommendations regarding the use of protective eye wear, clothing and respirators.



DANGER

Not for use with fluids that have a flash point below 100°F (38°C). Examples: gasoline, alcohol. Sparking could result in an explosion which could result in death.



WARNING

In the presence of explosive vapors, take action to prevent static sparking. Failure to ground the pump, piping, valves, containers, or other miscellaneous equipment can result in fire or explosion. A green grounding lug is provided on the pump.



WARNING

WARNING: The Tiger HP® 6:1 pump (1130-019, 1130-025, & 1160-007) develops 790 psi (51.7 Bar) maximum working pressure at 150 psi (10.3 Bar) maximum inlet air pressure and stall conditions. Be sure that any components or accessories used in the system are rated to withstand this pressure. To estimate fluid output pressure at stall conditions, multiply the ratio of the pump by the air pressure being used.

EXAMPLE: 6:1 Pump Ratio x 100 psi air pressure = 750 psi fluid pressure at stall.



WARNING

This pump contains aluminum and zinc parts. Do not use 1-1-1 Trichloroethane, methylene chloride or other halogenated hydrocarbon solvents or fluids containing such solvents in this pump. Use of these solvents/fluids may result in a violent chemical reaction, causing serious bodily injury, property damage or death. All fluids used in this pump must be chemically compatible with the wetted parts materials shown on page two (2) of this manual. Consult your chemical supplier to ensure compatibility.



WARNING

Pressure Relief Procedure:

Follow this procedure whenever you shut off the pump, when checking or servicing any part of the system and when installing, cleaning or changing any part of the system.

- 1) Disconnect the air to the pump.
- 2) Point dispensing valve away from yourself and others.
- 3) Open dispensing valve until pressure is relieved.



WARNING

If a check valve is installed at the end of the suction tube for the 1130-019 & 1130-025 use 4411-019, otherwise an external pressure relief valve must be installed at the outlet of the pump.

Table of Contents

Cover	1	Pump Repair/Serviceing	5-8
General Safety Information.....	2	Troubleshooting Guide	9
Product Description	3	Parts List.....	10
Technical Data.....	3	Parts Diagrams.....	11-16
Pump Installation.....	4	Pump Dimensions	17
Operation.....	4	Warranty Statement.....	20
Preventive Maintenance.....	5		

Product Description

The 6:1 ratio Tiger HP® pump can service as many as six simultaneous dispense points or transfer oil to distances up to 700 feet.

The Tiger HP® air motor features a precision air valve mechanism with dual valve ports for improved high speed breathing. It also contains a positive trip detent spool mechanism that eliminates stalling (blowing air) by preventing the pump from stopping between strokes. It has a simple yet durable construction with all internal parts lubricated at the factory using a life-tested synthetic grease.

The Tiger HP® pumping assembly features a stainless pump rod for superior wear and corrosion resistance. The pump's exterior is constructed from aircraft grade extruded aluminum for an outstanding strength and reliability. The pump also has high quality seals and is designed for long-term durability and ease of service. It is equipped with internal pressure relief to protect the system from thermal expansion.

Pump Pressure/Flow (6:1)
Test Fluid: 10W30 Oil

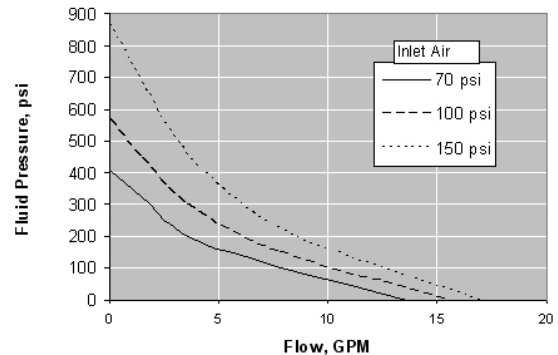

Technical Data

Tiger® HP 6:1 Ratio Pump

Specification Item	Value or Range
Nominal Pump Pressure Ratio	6:1
Air Motor Effective Piston Diameter	3.2 inches [86 mm]
Nominal Pump Stroke Length	3.25 inches [81.3 mm]
Air Motor Displacement	51.5 cubic inches [0.84 liters]
Pump Cycles per Gallon	31 cpg [7.7 cyc/liter]
Maximum Operating Air Pressure Range	40 - 150 psi [0.7 - 10.3 Bar]
Recommended Operating Air Pressure Range	40 - 125 psi [2.8 - 8.6 Bar]
Max Fluid Stall Pressure @ 150 psi air	870 psi [51.7 Bar]
Relief Valve Cracking Pressure	850 psi
Air Consumption, @ 100 psi air & 8 GPM	59 SCFM
Fluid Suction lift	20 inches Hg.
Port Size, Fluid In	1" NPT(F) / 1-1/2" NPT(M)
Port Size, Fluid Out	3/4" NPT(F)
Port Size, Supply Air	3/8" NPT(F)
Wetted Parts	Steel, Stainless Steel, Aluminum, Buna, Ultrathane
(Model 1160-007)	Stainless Steel and Viton
Compatible Fluids	Petroleum & Synthetic Oils, Gear Oil, ATF, Hyd. Fluid
(Model 1160-007)	Antifreeze

Pump Installation



WARNING: Attach a proper ground wire to the pump grounding lug (item 51, p.10) before starting the pump.



NOTE: Pump performance will be degraded by air or fluid threaded connections which are not air-tight. Use Teflon™ tape or other suitable means to achieve a complete thread seal.

The Tiger HP® pump may be mounted three ways: 1) using a reservoir bung fitting and Balcrank Universal Bung Adapter, model 4411-009N. 2) foot mount to a reservoir bung fitting using a double-tapped adapter, model 4411-018N. 3) wall mount the pump using a Wall Bracket, model 4411-008.

If mounting to a reservoir bung port, thread the pump bung adapter (4411-009N) into the bung thread on the fluid reservoir, attach a suitable suction tube or hose to the pump fluid entry port, lower the pump into the mounted bung adapter, then tighten. Install the 1/8" NPT x 3/8" barb in the port on the bung adapter. Slide one of the spring clamps on to each end of the included 3/8" clear tubing. Connect one end of the tubing to the barb fitting on the pressure relief valve (56) and the other end to the barb on the bung adapter. Slide the spring clamps up on both barb fittings to secure the tubing.



CAUTION: Always tighten pump down securely to avoid damage to the fluid reservoir, the pump, and nearby equipment. Be sure to use only the specified bung adapter.

If mounting with a double-tapped bushing (4411-018N) attach the suction tube or hose to the double-tapped bushing, thread the bushing into the bung thread on the fluid reservoir, and attach the pump to the double tapped bushing. The suction tube should be submerged in the tank liquid and should reach to within 1 to 2 inches from the bottom of the reservoir. Install the 1/8" NPT x 3/8" barb in the port on the double tapped bushing. Slide one of the spring clamps on to each end of the included 3/8" clear tubing. Connect one end of the tubing to the barb fitting on the pressure relief valve (56) and the other end to the barb on the bung adapter. Slide the spring clamps up on both barb fittings to secure the tubing.

If mounting onto a wall bracket, place the pump in the bung-mount adapter provided on the bracket, then tighten the adapter clamping threads. Attach a wall

mount Suction Assembly Kit to the pump, then lower the suction tube into the reservoir, adjusting height to set the end of the tube 1 to 2 inches above the bottom of the reservoir. The connection on the pressure relief valve (56) will need to be routed back to the reservoir or another suitable collection point using 3/8" I.D. tubing of the appropriate length. The optional model 4411-024N 2" pvc collar can be used on a standard 2" bung port to facilitate routing the pressure relief connection back to the reservoir.

Provide a drop-tee fitting, 3/8" size or larger, in the nearby air supply pipeline. From that tee, install the following pump air line assembly:

- pipe bushing or adapter (to bring the line drop size to 3/4" male)
- 1/2" pipe drop to pump level
- 1/2" pipe elbow
- 1/2" air F-R-L
- 1/2" air shutoff ball valve (having an air relief vent when closed)
- 1/2" to 3/8" reducer and a 3/8" x 3 ft. air hose
- 3/8" air line coupler and nipple.

Attach the air nipple to the air inlet port of the Tiger HP® pump. During assembly of the air supply line, be sure to clean out all foreign materials before making connection to the pump.

Balcrank recommends that an air line lubricator be used with turbine oil (viscosity 150-170 SSU @ 100 ° F) and set at a maximum oil feed rate of 1 drop every 2 hours of pump operation.

The pump air motor has been coated internally with a special synthetic grease at initial assembly (available as Balcrank P/N 826733) and does not require additional grease except during reassembly after a repair.



Figure 1
Installed Tiger HP® Pump

Pump Operation



CAUTION: Read all limitations which apply to selection of fluids which may be pumped by this product. Do not pump a fluid which is not specified to be compatible.



CAUTION: Always read and follow fluid manufacturers' recommendations regarding proper use of protective eye wear, clothing and respirators.

To Start Pump:

- 1 Immerse the pump's suction tube or fluid inlet into the fluid to be pumped.
- 2 Connect the air coupler to the pump and turn the air regulator to the minimum setting.
- 3 Direct pump outlet hose into an approved waste oil container.
- 4 Slowly adjust the air regulator until the pump is primed and running smoothly. Be sure all air has been purged from the system. The pump should prime in less than 30 seconds.

To Start Pump:

- 1 Immerse the pump's suction tube or fluid inlet into the fluid to be pumped.
- 2 Connect the air coupler to the pump and turn the air regulator to the minimum setting.
- 3 Direct pump outlet hose into an approved waste oil container.
- 4 Slowly adjust the air regulator until the pump is primed and running smoothly. Be sure all air has been purged from the system. The pump should prime in less than 30 seconds.
- 5 Use the air regulator to control the pump's speed and cycle rate. Always use the lowest pressure required to obtain the desired flow rate. This will increase pump and seal life.
- 6 Never allow a pump to be run dry of the fluid being pumped. A dry pump quickly speeds up, which could damage the air motor and fluid seals. If the pump suddenly speeds up, cut off the air supply as soon as possible, refill the system fluid reservoir and reprime the pump.
- 7 If the pump will be unattended for any period of time, or to shut off the system at the end of a work shift, always follow the Pressure Relief Procedure on page 2 of this manual.



WARNING

Pressure Relief Procedure:

Follow this procedure whenever you shut off the pump, when checking or servicing any part of the system and when installing, cleaning or changing any part of the system.

- 1) Disconnect the air to the pump.
- 2) Point dispensing valve away from yourself and others.
- 3) Open dispensing valve until pressure is relieved.



NOTE: The air motor is lubricated with a life-tested synthetic grease (P/N 826733) at the factory. This grease coats all parts and repels air line moisture to inhibit corrosion. It is imperative that any grease removed during maintenance be replaced afterwards. Contact your local Balcrank distributor, using the above part number, for replacement grease.

Pump Repair / Servicing

Pump Disassembly Procedure:

Figure 11

1 Mount the pump horizontally in a bench vise. Clamp the vise to the upper body of the pump and use elastic jaw cushions in the vise to prevent scarring the pump surface. With a socket wrench, loosen and remove the four lower 5/16" Hex Bolts [31] and Lock Washers [4]. Then remove and set aside the Bare Pump subassembly. Also remove the Lower Body [5] and Muffler [7].

2 If the air motor subassembly will not be repaired immediately, re-attach the Lower Body [5] and Muffler [7] to the Air Motor subassembly, temporarily securing them with the 5/16" Bolts [31] and Lock Washers [4], turned hand tight. Remove the assembly from the vise.

3 For further disassembly, use the separate procedures which follow for the Air Motor and Lower Pump subassemblies.

Air Motor Disassembly Procedure:

Figure 5

4 If the Lower Body [5] and Muffler [7] are attached to the Air Motor subassembly, remove them now,

along with the four 5/16" Hex Bolts [31] and Lockwashers [4] which secure them.

5 Mount the Air Motor horizontally in a bench vise. Clamp the vise to the Upper Body [1] of the pump and use elastic jaw cushions in the vise to prevent scarring the pump surface.

6 Using a socket wrench, hold the 5/16" Hex Acorn Nut [30] on the pump Cap [9]. With a second socket wrench, loosen and remove the 5/16" Hex Nut [11] and Lockwasher [4] at the other end of the 5/16"-18 Threaded Stud [3]. Then remove the Acorn Nut [30] and Stud [3] as a group. Do not remove the Acorn Nut from the Threaded Stud. Repeat the procedure for the other three Studs. Set aside all fasteners in a group.

7 Remove the Center Insert [6] from the subassembly by sliding it carefully off the Air Piston. Remove the two O-ring Seals, [2] and [8], from their glands on the Center Insert [6]. Set these parts aside in a group.

8 Remove the Cap [9] from the top of the Air Motor. As the Cap [9] is removed, it must be shifted sideways approximately 1 inch to allow detachment from the internal Trip Rod. After removal of the Cap, remove the O-ring Seal [2] from the gland in the Cap. Set these parts aside in a group.

9 Remove the Air Motor Subassembly [shown in figure 4] from the Upper Body [1]. Remove toward the top of the pump, opposite the direction of the 3/8" NPT port on the Upper Body. Slide out carefully, keeping the Air Piston square with the bore of the Upper Body. Remove the Upper body from the vise and set aside.

Figure 4

10 Remove the O-Ring Seal [28] from the Air Piston [17]. Using a flat blade screwdriver, remove two Detent Sleeves [18], Detent Springs [27], and Detent Balls [26]. Set all of the removed parts aside as a group.

11 Clamp the Air Piston in a vise applied to the 4" piston diameter. Note! Use Split wooden vise blocks matched to the piston diameter to prevent scarring the piston surface!

12 Using two open-end wrenches, loosen the Jam Nuts [23] located on top of the Intake Valve Stems [22]. Remove the Jam Nuts and the two Intake Valve Stems. It may be necessary to secure the hex cap of the Valve Stem [22] with an open end wrench while removing the second nut. Then remove the O-Ring Seals [25] from the gland of the two Valve Stems [22].

13 Remove the Valve Trip Assembly [shown in figure 3] from the top of the Air Piston. Remove

the Air Piston plus Rod Coupler, items [17] and [29], from the vise and set aside. Note! It is not necessary to separate the joint of the Air Piston and Coupler.

Figure 3

14 Secure the assembly horizontally in a bench vise, clamping the parts at the flats located on the Rod Head [13]. Applying torque to the flats of the Retainer, Spring, Threaded [12], loosen the trip rod assembly. Note! Turn wrench slowly and steadily to prevent breaking male threads on the Trip Rod [16].

15 Remove all parts from the Trip Rod [16]. Using vise-grip pliers, clamp the Trip Rod [16] near the Rod Head [13] and loosen the remaining threaded joint. Set aside all loose parts in a group, but retain the Valve Bar parts [shown in Figure 2] for further disassembly.

Figure 2

16 Using two open-end wrenches, loosen the Jam Nuts [23] located on top of the Exhaust-Valve Stems [21]. Remove the Jam Nuts and the two Exhaust Valve Stems. It may be necessary to secure the hex cap of the Valve Stem [21] with an open end wrench while removing the second nut. Then remove the O-Ring Seals [25] from the gland of the two Valve Stems [21].

17 Clamp the subassembly in a vise on the flats of the Nut [24]. Using an adjustable open-end wrench, loosen the Detent Spool [20]. Separate all parts. Set aside all items from steps 16 and 17 in a group. Disassembly of the Air Motor is now complete.

Lower Pump Disassembly Procedure:

Figure 10

1 Clamp the subassembly shown in figure 10 in a bench vise, holding the parts at the flat edge of the flange of the Fluid Adapter [33]. Using a strap wrench, apply torque to the Pump Tube [35] to loosen and remove the Pump Tube and adjacent attached parts. Set these parts aside after removal.

Figure 9

2 With the Fluid Adapter [33] still clamped in the bench vise, remove the Fluid Piston [36], Pump Rod [34] and associated attached parts by sliding them out of the Adapter [33]. Use care to avoid scarring the surface finish on the o.d. of the Pump Rod. Set aside the Rod and Piston parts.

Figure 8

3 For the 1160-007, remove screws [55] and lock-washers [54] with a 7/16" wrench. For all models, using snap ring pliers, remove the Retaining Ring [40] from the Fluid Adapter [33]. Then remove the Cup Seal [39] and Wear Band [38]. Remove the O-Ring from the lower o.d. of the Fluid Adapter [33]. Remove the Fluid Adapter from the bench vise. Set all parts aside from figure 8 as a group.

Figure 7

4 Clamp the Foot Valve Seat [37] in a bench vise. Using a strap wrench, loosen and remove the Pump Tube [35]. Using a pointed tool, push out the Pin [44], then remove the ball [41] and O-Ring Seal [43]. Set all parts aside from figure 7 as a group.

Figure 6

5 Clamp the Pump Rod [37] in a bench vise. Note! Use Split wooden vise blocks matched to the Pump Rod diameter to prevent scarring the Rod surface! Remove the Wear Band [46] (*except Model 1160-007*) and O-Ring Seal [45]. Then, using a spanner wrench, loosen and remove the Fluid Piston [36]. It is not necessary to remove check valve parts internal to the Fluid Piston on Model's 1130-019 & 1130-025. If they are damaged or malfunctioning the entire assembly must be replaced. Set all parts aside. Disassembly of the Pump Lower is now complete.

Lower Pump Assembly Procedure:

Figure 6

1 Collect the parts group shown in figure 6. Substitute rebuild kit parts in place of old items where applicable. Clamp the Pump Rod [37] in a bench vise. Note! Use Split wooden vise blocks matched to the Pump Rod diameter to prevent scarring the Rod surface! Insert the Ball [41] into the cavity of the Pump Rod [37], apply Loctite 263 threadlock to the o.d. threads of the Fluid Piston, then screw the Fluid Piston [36] into the Pump Rod [37]. Tighten using a spanner wrench, to approximately 20 ft-lb torque.

2 Apply a film of grease to the o.d. grooves of the Fluid Piston [36]. Install the Wear Band [46] and O-Ring Seal [45]. Set this subassembly aside.

Figure 7

3 Collect the parts group shown in figure 7. Substitute rebuild kit parts in place of old items where applicable. Install the O-Ring Seal [43] on the o.d. shoulder of the Valve Seat [37]. Install the Ball [41] and Pin [44]. Clamp the Foot Valve Seat [37] in a bench vise. Using a strap wrench, install and tighten the Pump Tube [35] to approximately 20 ft-lb. torque.

Set this subassembly aside.

Figure 8

3 Collect the parts group shown in figure 8. Substitute rebuild kit parts in place of old items where applicable. Clamp the Fluid Adapter [33] in a bench vise, gripping the edges of the flange, with rod cavity horizontal. Install the O-Ring Seal [43] on the o.d. shoulder of the Fluid Adapter [33]. Install the Cup Seal [39] and Wear Band [38] in the seal cavity of the Adapter. Note! cup seal lips point down, away from the adapter flange. Using snap ring pliers, install the Retaining Ring [40] into the Fluid Adapter [33] groove.

Figure 9

4 With the Fluid Adapter [33] still clamped in the bench vise, install the Fluid Piston [36], Pump Rod [34] and associated attached parts from lower pump assembly step 2, by sliding them into the Adapter [33]. Use care to avoid scarring the surface finish on the o.d. of the Pump Rod.

Figure 10

5 With the Fluid Adapter [33] still clamped in the bench vise, install parts previously combined in lower pump assembly step 3. Using a strap wrench, apply torque to the Foot Valve Seat [37] and tighten to 40 ft-lb torque. Lower Pump Assembly is now complete.

Air Motor Assembly Procedure:

Figure 2

1 Collect the parts group shown in figure 2. Substitute rebuild kit parts in place of old items where applicable. Install the Valve Bar [19] on the mating diameter of the Detent Spool [20]. Clamp the 5/8" Jam Nut [24] in a bench vise on the flats of the Nut and apply Loctite 638 threadlock to the internal threads of the Jam Nut [24]. Then, Using an adjustable open-end wrench, install and tighten the Detent Spool [20]. Apply 85 ft-lb torque.

2 Install the Exhaust Valve Stems [21] into the Valve Bar [19]. Install 5/16" Jam Nuts on the stems and tighten to 70 in-lbs using two open-end wrenches. It will be necessary to secure the hex cap of the Valve Stem [21] with an open end wrench while securing the first nut. Then install the O-Ring Seals [25] into the gland of the two Valve Stems [21].

Figure 3

3 Secure the Rod Head [13] in a bench vise, clamping the part across the flats. Apply Loctite 263 to the internal threads. Install the Trip Rod [16] and tighten

to 40 in-lb torque. Use vise grips, applied near the Rod Head, to turn the Trip Rod.

4 Install the following items onto the Trip Rod [16] in the sequence and orientation shown in figure 3: Spring Retainer [14, qty=3], Trip Spring [15, qty=2], assembled parts from stage 1, figure 2.

5 Apply Loctite 263 to the internal threads of the Spring Retainer, Threaded [12]. Install the Spring Retainer, Threaded on the end of the Trip Rod [16] and tighten the entire assembly to 100 in-lbs torque.

Figure 4

7 Clamp the Air Piston [17] in a vise, with clamping pressure applied to the 4" diameter on the piston. Note! Use Split wooden or elastic vise blocks matched to the piston diameter to prevent scarring the piston surface! If rod coupler [29] was removed during disassembly, apply Loctite 638 on the internal threads of the rod coupler [29] and re-install.

8 Apply a film of grease in the center cavity of the Air Piston [17]. Insert the assembled parts from assembly stage 2 (per figure 3) into the cavity, oriented as shown in figure 4.

9 Apply a film of grease to the seal gland and o.d. surfaces of the Intake Valves [22]. Install O-Ring Seals [25] on the Intake Valves. Then pass the valves through the ports of the Air Piston [17] and into the mating holes on the Valve Bar [19]. Secure the Valves with 5/16" Jam Nuts [23]. Tighten all Jam Nuts to 70 in-lb torque.

10 Apply a film of grease to the 1/2" Ball [26, qty=2] and Detent Spring [27, qty=2]. Then by hand, apply upward pulling force on the Trip Rod assembly, so that the intake valves [22] are completely closed. With the Trip Rod held in that position, install the 1/2" Steel Ball [26], Detent Spring [27] and Detent Sleeve [18] in each of the two detent ports located on the Air Piston [17]. It will be necessary to unclamp and adjust position of the Air Piston during this procedure.

11 Apply a film of grease to the o.d. seal gland on the Air Piston [17], then install the O-Ring Seal [28]. Remove the Air piston from the vise and apply a film of grease to the 4" diameter piston surface. Set aside the completed subassembly.

Figure 5

12 Clamp the Upper Body in a bench vise, oriented with bore horizontal. Use elastic jaw cushions in the vise to prevent scarring the pump surface. Install the Air Motor Subassembly [shown in figure 4] into the Upper Body [1]. Install from the top of the pump, opposite the direction of the 3/8" NPT port on the Upper Body. Slide in carefully, keeping the Air Piston square with the bore of the Upper Body.

13 Install the O-ring Seal [2] into the gland in the Cap [9]. Install the Cap [9] on the top of the Air Motor. When the Cap [9] is installed, it must be shifted sideways approximately 1 inch to allow attachment of the internal Rod Head [13, fig 2] into the slot on the Cap [9].

14 Apply a film of grease to the seal glands on the Center Insert [6]. Install the two O-ring Seals, [2] and [8], in their glands on the Center Insert [6]. Install the Center Insert [6] on the subassembly by sliding it gently onto the Air Piston.

15 If the 5/16" Threaded Studs [3, qty=4] and Acorn Nuts [30, qty=4] have become separated during subassembly, they must be reassembled with adhesive before proceeding further. Clean and degrease the threads of the Stud and Nut. Apply Loctite 263 to the internal threads of the Acorn Nut [30] and install the Nut on the Stud [3]. Using vise-grip pliers to hold the Stud [3] near the Acorn Nut [30], tighten the Nut with a hex wrench to 100 in-lb torque.

16 Install the Studs [3, qty=4] and Acorn Nuts [30, qty=4] as shown in figure 5, into the holes on the subassembly. Using a socket wrench, hold the 5/16" Hex Acorn Nut [30] on the pump Cap [9]. With a second socket wrench, install and tighten the 5/16" Hex Nut [11, qty=4] and Lockwasher [4, qty=4] at the other end of the 5/16"-18 Threaded Stud [3]. Leave the Upper Body clamped in the bench vise.

Final Pump Assembly Procedure:

Figure 11

17 Install the Lower Body [5] in position on the Air Motor (from figure 5), with Dowel Pins on the Lower Body oriented away from the Air Motor. Install the Muffler [7] in the counterbore of the Lower Body [5].

18 Install the Bare Pump subassembly on the Air Motor as shown in figure 11. The muffler must be loosened, Pump Rod and muffler shifted off-center 1", then moved into position and the Pump Rod locked into the coupler slot on the bottom of the Air Piston. After attachment to the Air Piston, reposition the Muffler and move the flange of the Fluid Adapter into tight contact with the Lower Body, with dowel pins located into their mating holes on the Fluid Adapter. Install the 5/16" Hex Cap Screws [31] and Lockwashers [4], then tighten to 100 in-lb torque. Pump assembly is complete.

Troubleshooting Guide



NOTE: Check all other possible causes of operating problems, and apply remedial action, before disassembling pump.



WARNING: Before beginning pump repair, all internal pressure must be relieved. To reduce risk of personal injury, follow the Pressure Relief Procedure shown on pages 2 and 5.

Trouble	Probable Cause	Corrective Action
Pump does not operate	Inadequate air supply pressure or restricted air line Clogged lines, hoses, valves, etc. Damaged air motor	Increase line size or clear air supply ⁽¹⁾ Assure air is on and valves are open Open; clear ⁽¹⁾ Service / replace air motor
Air motor is not tripping over	Air motor seals are worn/damaged	Service / replace air motor
Air is leaking from exhaust and or seal damage, etc.	Air motor seals are worn/damaged	Service / replace air motor
Fluid is leaking from the exhaust	Fluid seal [39, fig 8] is worn/damaged	Replace fluid seal
Erratic pump operation	Air entering suction line Fluid level too low Air motor icing	Check for loose suction connections Refill, reprime or flush Run pump at lower pressure; run at lower cycles per minute; clean muffler [7]
Pump runs continuously	Empty fluid supply Blockage in pump tube or foot valve [37] Lower ball [41] is stuck in foot valve [37] Lower seal [45] is worn or damaged	Refill, reprime or flush Remove pump tube, clear blockage Replace ball and reseal foot valve Replace
Fluid output on one stroke only or continues to operate when dispensing valve is closed	Upper ball [41] is stuck in fluid piston [36] or one or both are damaged	Replace ball and reseal
Pump operates slowly, and pump output on both strokes is low	Inadequate air supply pressure or restricted air line Closed or clogged solenoid valve, meter, dispensing valve, etc. Air inlet strainer/filter clogged	Increase air supply; increase air supply size Clear ⁽¹⁾ Clear ⁽¹⁾

(1) Follow the **Pressure Relief Procedure** and disconnect the fluid line. If the pump starts when the air is turned on again, the line, etc. is clogged.

Parts List

Tiger HP® 6:1 Ratio Pump

Service Kits
 900020 Pump Lower Rebuild Kit
 900027 Air Motor Rebuild Kit (*see note)
 900028 Air Motor Soft Parts Kit (*see note)
 828070 SS Pump Lower Rebuild Kit

Item	Part Number	Description	Pump Qty		Service Kit Qty				Part Pack Kits
			1130-019	1160-007	900020	900027	900028	828070	
1	831669	Upper Body	1	1					
2	831661	Seal, O-ring, dash 246	2	2		2	2		90037Q10
3	831658	Stud, 5/16-18 x 11.00 long	4	4					
4	805844	Lock Washer, 5/16	4	4					
5	831915	Lower Body	1	1					
6	831668	Center Insert	1	1					
7	820189	Muffler	1	1					
8	831659	Seal, O-ring, dash 338	1	1		1	1		90038Q5
9	831670	Cap	1	1					
10	831675	Label, Tiger HP	1	1					
11	805793	Hex Nut, 5/16-18	4	4					
12	831770	Retainer, Spring, Threaded	1	1		1			
13	831769	Rod Head	1	1		1			
14	831767	Retainer, Spring	3	3		3			
15	831766	Spring	2	2		2			
16	831768	Trip Rod	1	1		1			
17	831664	Air Piston	1	1					
18	831914	Sleeve, Detent	2	2		2			
19	831759	Valve Bar	1	1		1			
20	831660	Detent Spool	1	1		1			
21	831762	Valve Stem, Exhaust	2	2		2			
22	831761	Valve Stem, Intake	2	2		2			
23	831764	Nut, Hex Jam, 5/16-18	8	8		8			
24	831366	Nut, Hex Jam, 5/8-18	1	1		1			
25	831665	Seal, O-Ring, Dash 110	4	4		4	4		90039Q20
26	813905	Ball, Steel, 1/2"	2	2		2			
27	807939	Spring, Ball Detent	2	2		2			
28	831765	Seal, O-Ring, Dash 346	1	1		1	1		90040Q5
29	831913	Rod Coupler	1	1					
30	831677	Nut, Hex Acorn, 5/16-18	4	4					
31	831674	Screw, Hex Hd, 5/16-18 x 5.375 long	4	4					
32	831680	Dowel Pin	2	2					
33	831663	Fluid Adapter	1						
	828366N	Fluid Adapter		1					
34	831667	Pump Rod	1						
	827415	Pump Rod		1					
35	832560	Pump Tube	1						
	831205	Pump Tube		1					
36	832022	Fluid Piston	1						
	828988	Fluid Piston		1					
37	831993	Foot Valve Seat, Vented	1						
	829027	Foot Valve		1					
38	831542	Wear Band	1			1			
	827425	Wear Band		1					
39	831540	Seal, Polypak	1			1			
	826072	Seal, Polypak, Viton		1				1	
40	831544	Retaining Ring	1			1			
	827426	Retaining Ring		1					
41	806962	Ball, 1.000 Dia	2						
	800971	Ball, 1.000 Dia SS		2					
42	828359 ⁽¹⁾	Seal, O-Ring, Dash 136	1			1			
	826676 ⁽²⁾	Seal, O-Ring, Dash 033	1			1			
43	826678	Seal, O-Ring, Dash 133	1			1			
	826679	Seal, O-Ring, Viton		2				2	
44	829769	Pin, Stop	1			1			
	827427	Pin, Stop		1				1	
45	831638	Seal, O-Ring, Dash 325	1			1			
	827065	Seal, Quad-Ring, Viton		1				1	
46	826248	Wear Band	1			1			
47	831489	Ground Lug	1	1					
48	831203	Mounting Plate (on 1130-025 only)	1						
49	831220	Retaining Ring (on 1130-025 only)	1						
50	808376	Gasket (on 1130-025 only)	1						
51		No Longer in Use							
52	827441	Seal, O-Ring, Viton						1	
53	832201	Plate Adapter		1					

*Additional parts in kit. Kit is also used for Lion HP pumps

(1) This O-ring used on models built before 10/13/08 and after 10/13/11

(2) This O-ring used on models built between 10/13/08 and 10/13/11 - Identified in service kit by twist tie

** This O-Ring used on pumps built before 10/13/08. Identified in service kit by twist tie.

Item	Part Number	Description	Pump Qty		Service Kit Qty				Part Pack Kits
			1130-019	1160-007	900020	900027	900028	829298	
54	829002	Lock Washer		4					
55	829001	Screw Hex Hd, 1/4-20 x 0.75 Long		4					
56	833052	Valve, Pressure Relief, 850 psi	1	1					
57	833189	Kit, Pressure Relief Hose	1	1					

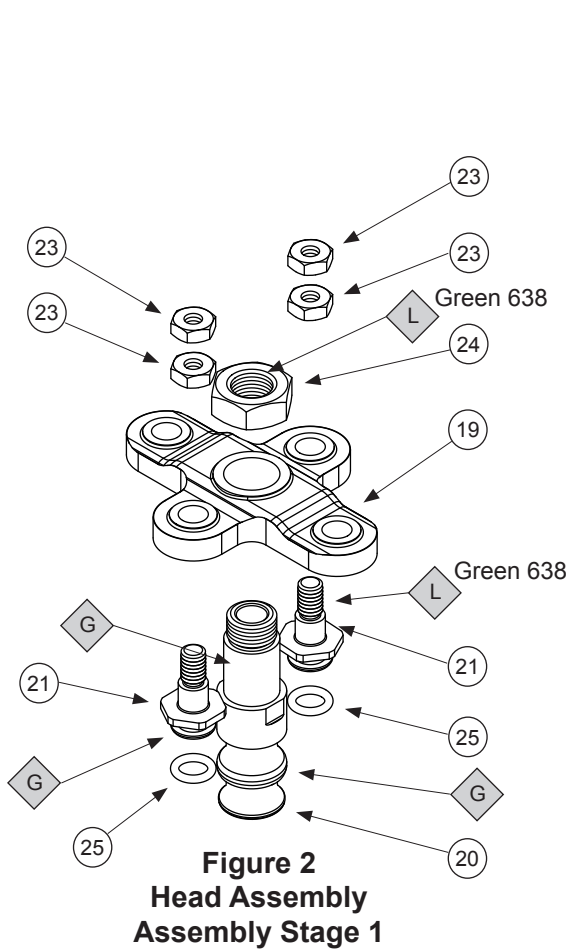

Exploded Views

Tiger HP® 6:1 Ratio Pump

Air Motor

25	- Item number, see page 10
G	- Grease application point, see detail in written procedure
L	- Loctite application point, see detail in written procedure

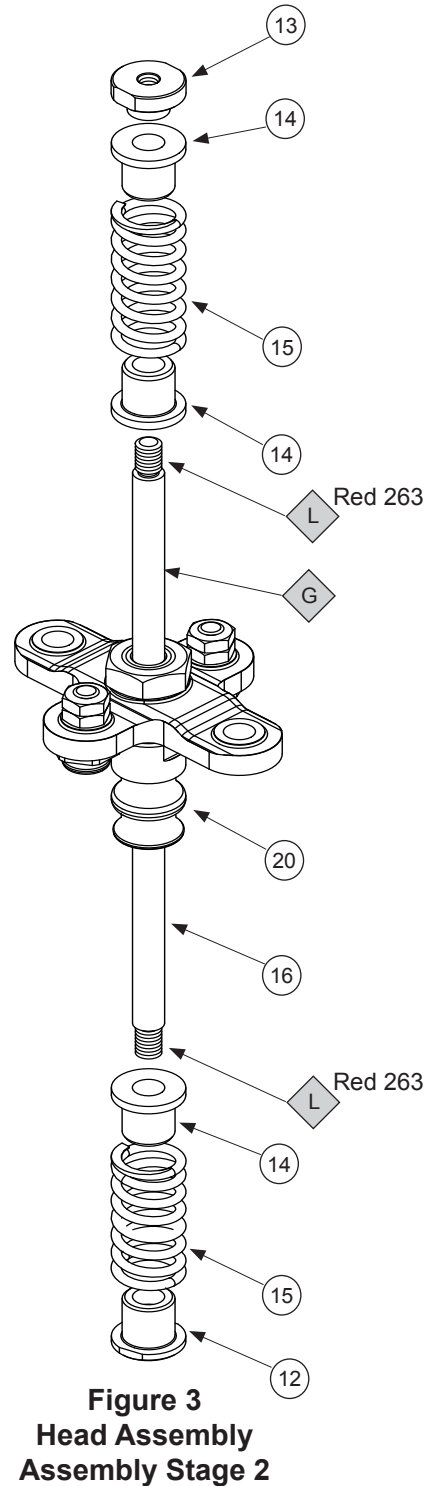

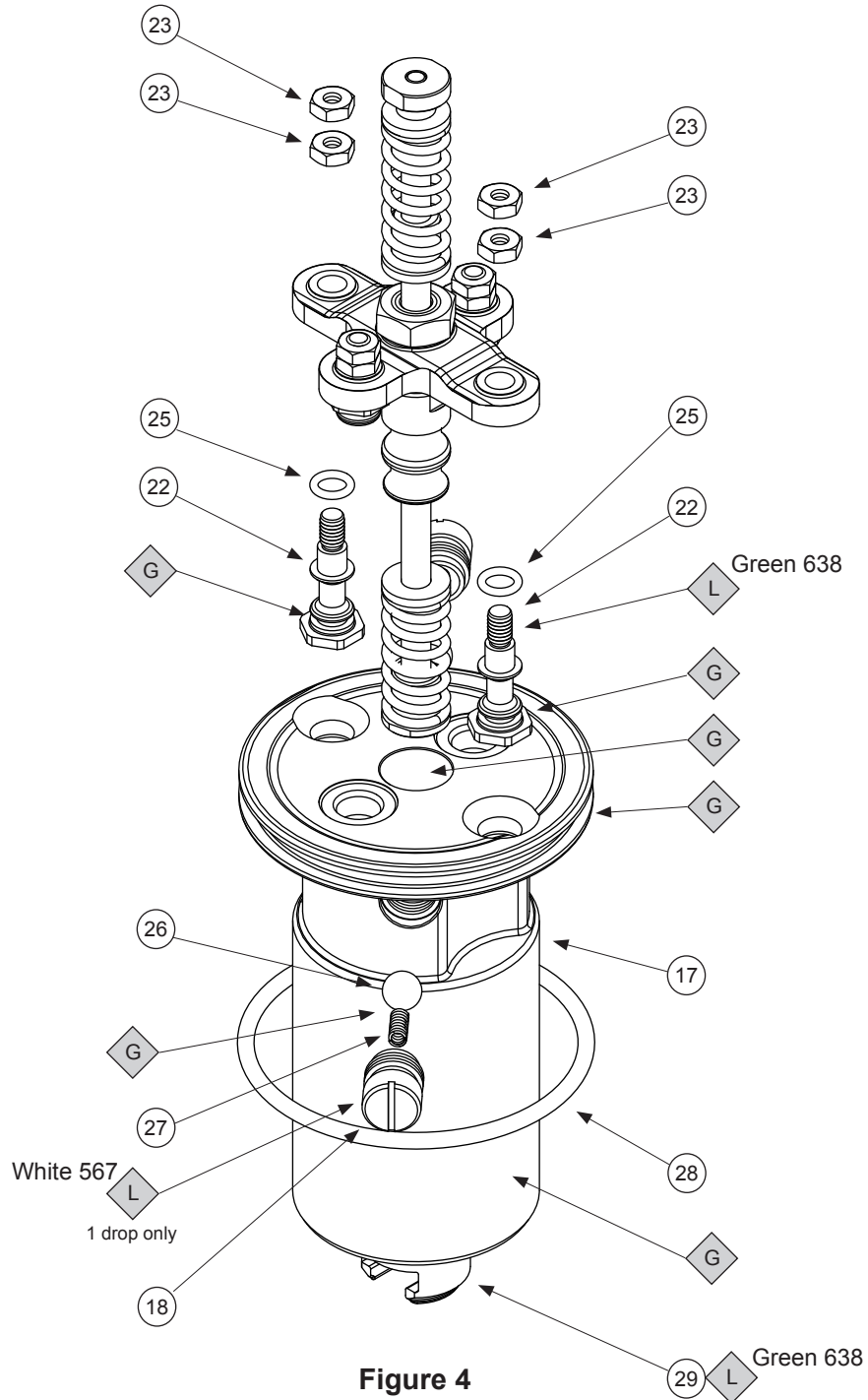
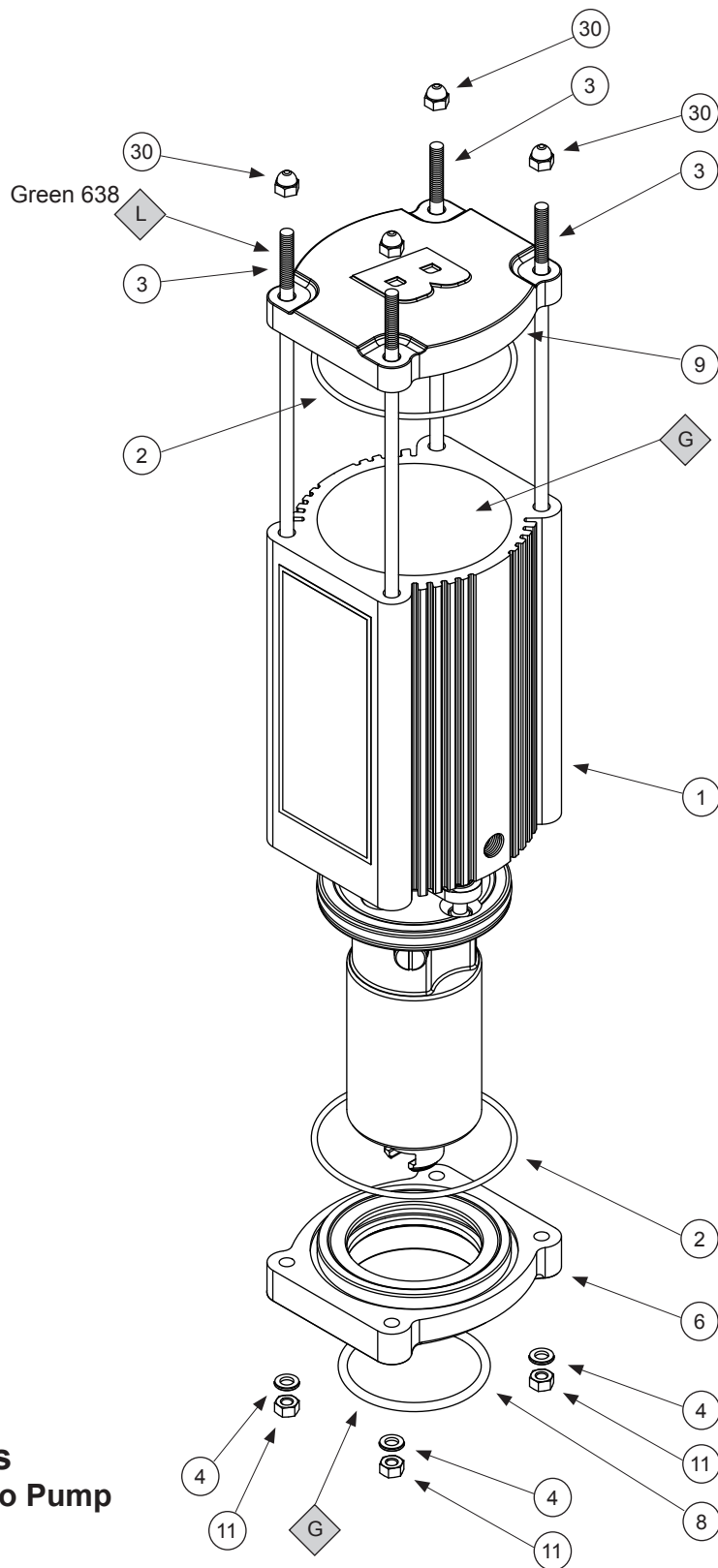

Figure 4
Head Assembly
Assembly Stage 3

Exploded Views
Tiger HP® 6:1 Ratio Pump
Air Motor

- Ⓜ - Item number, see page 10
- ◇ G - Grease application point, see detail in written procedure
- ◇ L - Loctite application point, see detail in written procedure



**Exploded Views
Tiger HP® 6:1 Ratio Pump
Air Motor**

- 25 - Item number, see page 10
- G - Grease application point, see detail in written procedure
- L - Loctite application point, see detail in written procedure

**Figure 5
Head Assembly
Assembly Stage 4**

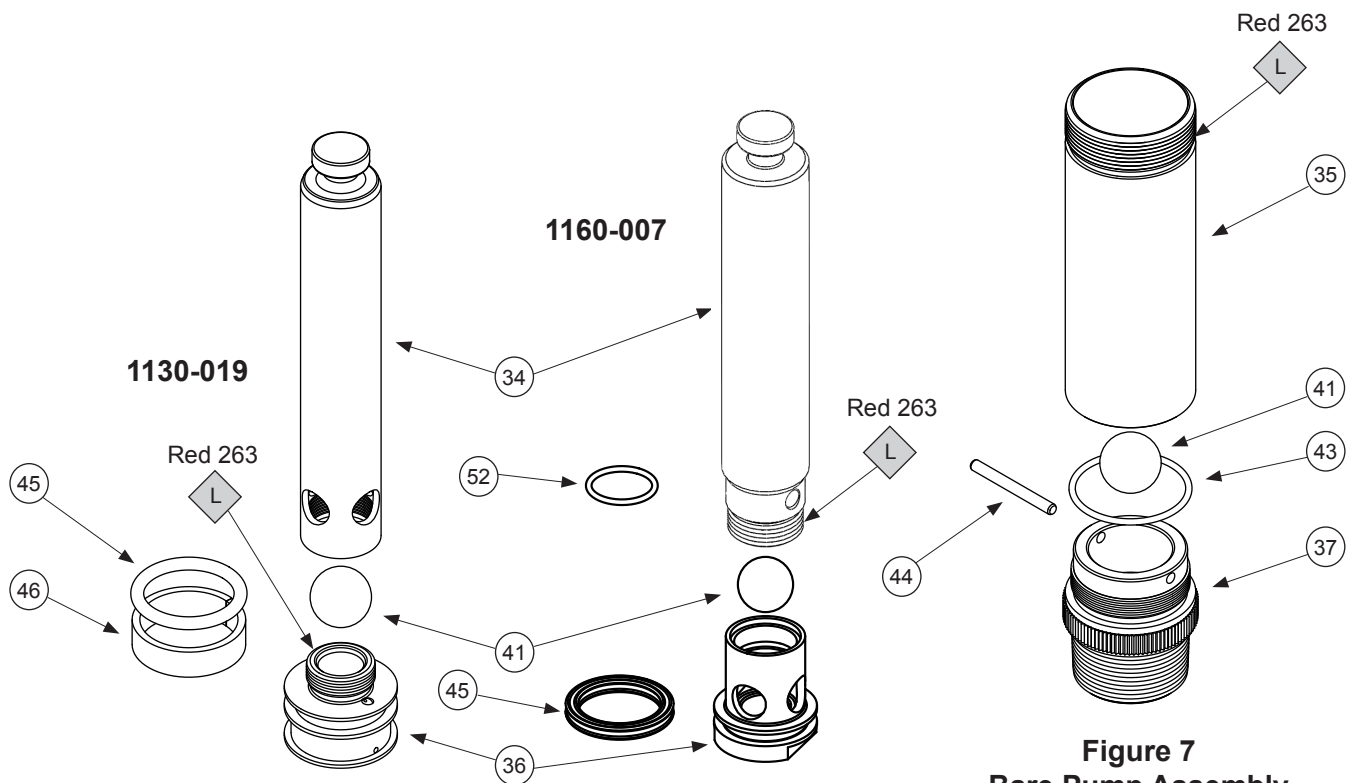

**Figure 6
Bare Pump Assembly
Assembly Stage 5**

**Figure 7
Bare Pump Assembly
Assembly Stage 6**

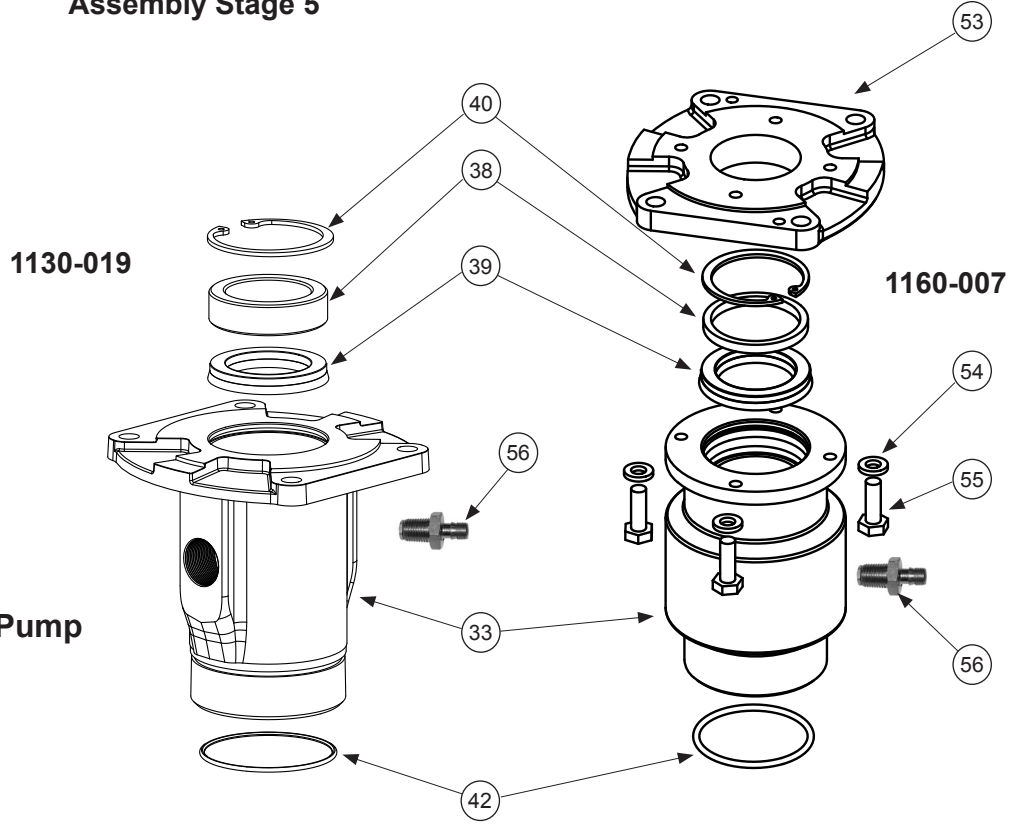

**Figure 8
Bare Pump Assembly
Assembly Stage 7**

**Exploded Views
Tiger HP® 6:1 Ratio Pump
Lower Assembly**

- (25) - Item number, see page 10
- G - Grease application point, see detail in written procedure
- L - Loctite application point, see detail in written procedure

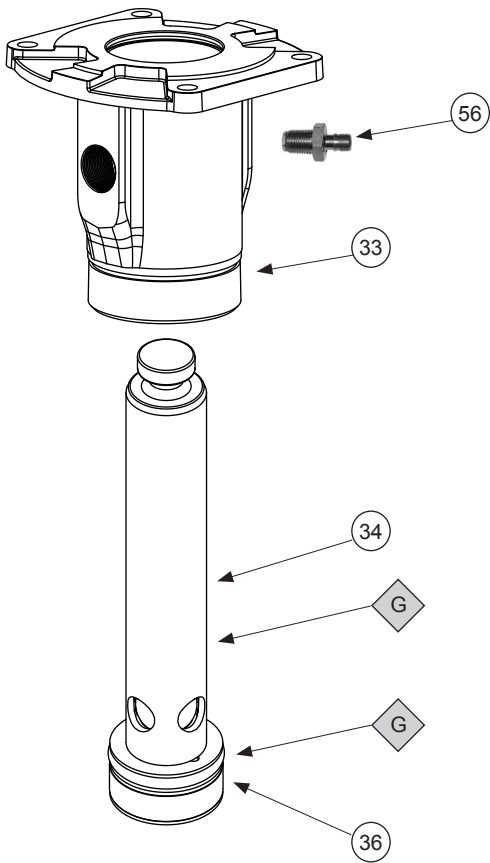

Figure 9
Bare Pump Assembly
Assembly Stage 8

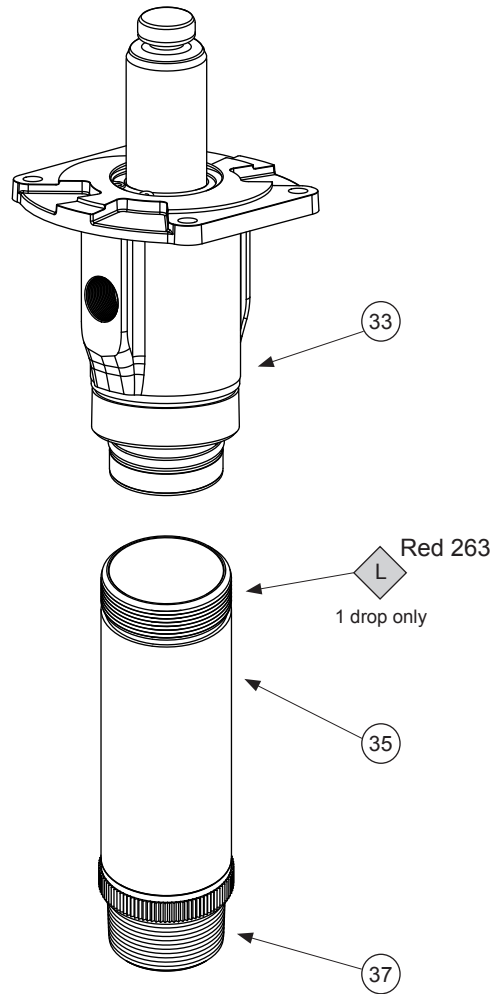
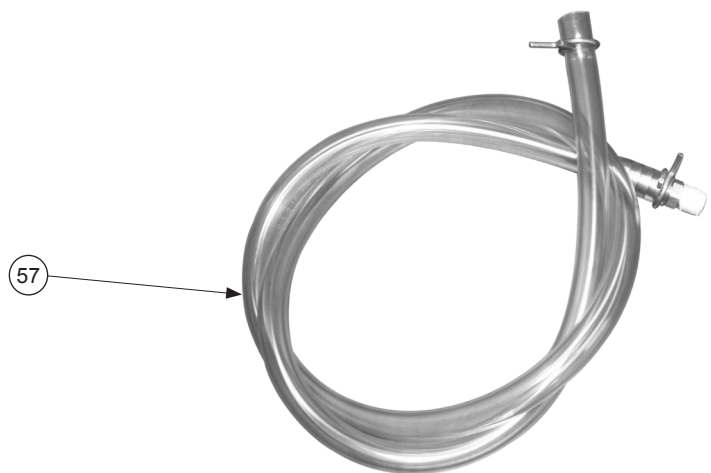

Figure 10
Bare Pump Assembly
Assembly Stage 9

Exploded Views
Tiger HP® 6:1 Ratio Pump
Lower Assembly

- (25) - Item number, see page 10
- G - Grease application point, see detail in written procedure
- L - Loctite application point, see detail in written procedure



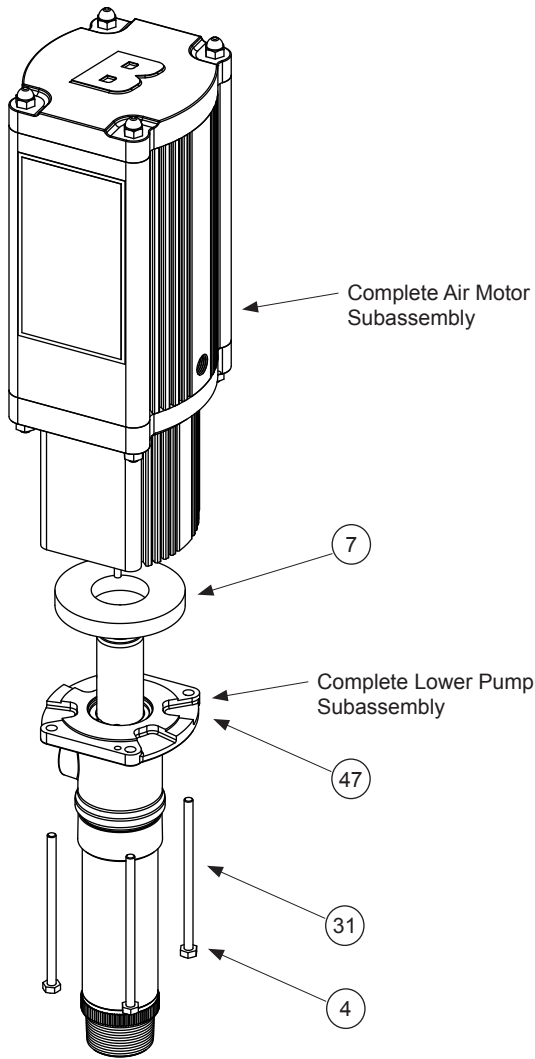

Figure 11
Final Pump Assembly
Assembly Stage 10

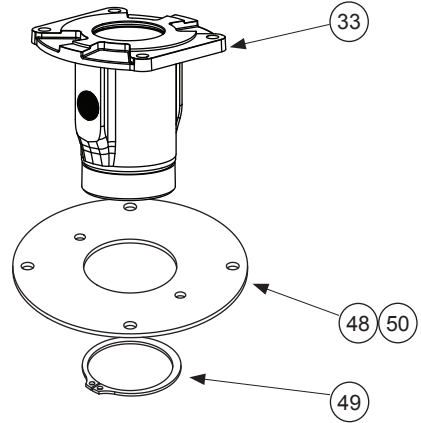
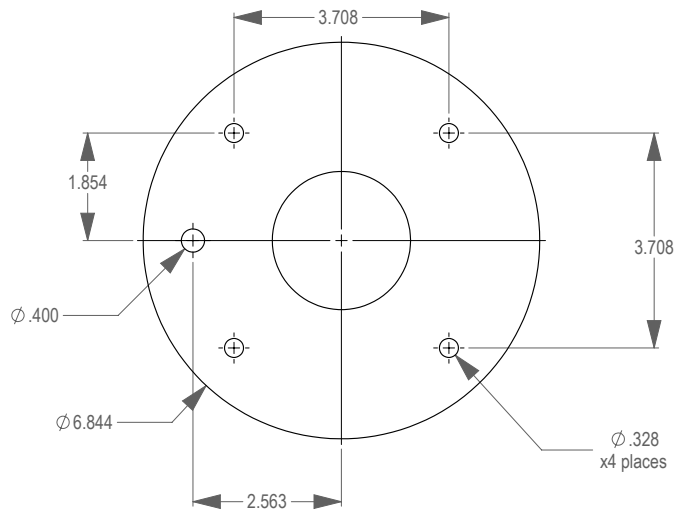

Figure 12
Flange Mount Parts Detail
for Model 1130-025 Only



Flange Mount Bolt Pattern
for Model 1130-025 Only

Exploded Views
Tiger HP® 6:1 Ratio Pump
Complete Pump
and Flange Mount Parts

25	- Item number, see page 10
G	- Grease application point, see detail in written procedure
L	- Loctite application point, see detail in written procedure

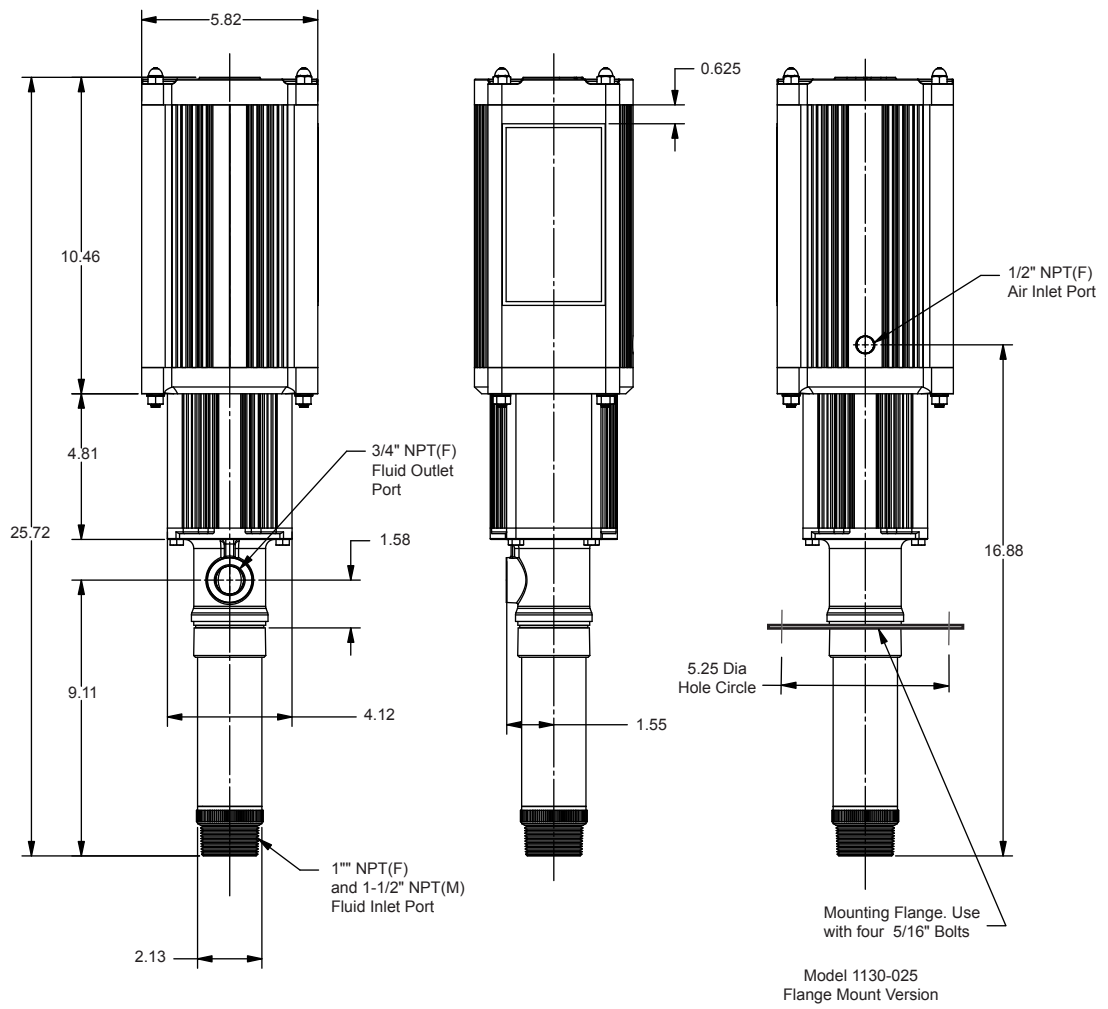

Figure 13
Complete Pump
Dimensions & Features

Tiger HP® 6:1 Ratio Pump
Complete Pump

Accessories

4411-009N
Universal Bung Adapter



4411-018N
Double Tapped Bushing



4411-024N
2" PVC collar for fill port



4411-017⁽¹⁾
Nickel Plated Bung Adapter



(1) Nickel plated bung adapter (for use with model 1160-007 Tiger HP Stainless Steel Pump)

NOTES:

Revision Log:

Rev. A - 5/05 - New Release

Rev. B - 5/06 - Added 1160-007

Rev C - 4/07 - Changed Part #'s page 10 (Item 1,5)

Rev D - 6/07 - Added Loctite "638" Identifier to pg 7.

Rev E - 12/08 - Removed part 828817 and changed part numbers for items 54 & 55. Added note about kits 900027 & 900028 to page 10 and updated warranty statement

Rev F - 2/09 - Updated Items 35 & 42 on page 10.

Rev G - 4/09 - Updated part numbers for items 1 & 5 on page 10.

Rev H - 8/09 - Added part number 827425 for model 1160-007, item 38 on page 10.

Rev I - 4/10 - Pump re-evaluated and re-spec'ed to 6:1 ratio.

Rev J - 5/11 - Updated technical data.

Rev K - 10/11 - Item 51 no longer used

Rev L - Added part numbers for new pressure relief and accessories

Rev M - Corrected part number and quantities for 1160-007 lower rebuild kit on pg. 10

Rev N - Changed part number for item 33 and added built-in pressure relief to stainless steel model 1160-007

Rev O - Changed part number for item 42

Rev P - Added flange mount bolt pattern to page 16

**For Warranty Information Visit:
www.balcrank.com**

Balcrank® Corporation
115 Reems Creek Rd.
Weaverville, NC 28787
800-747-5300
800-763-0840 Fax
www.balcrank.com

Service Bulletin SB 1065
Rev. P 1/14